



## 32cd Low-intensity Obstruction Light 10-60V<sub>DC</sub> - ICAO Type B. FAA L-810.

CEL-LI-32-DCW-F - LED Aircraft Warning Light

### Key features

- Based on LED technology
- Extremely reliable - long lifetime
- Suitable for off-shore use
- Very low power consumption
- Wide 10 to 60VDC input voltage
- Stabilised light output
- Lightweight and small - low wind load factor
- Easy to install, several mounting sets available
- Two cable glands, easy to chain without external terminal boxes
- No RF-radiations
- Five (5) year warranty
- Patented

### Benefits

- Long maintenance intervals
- Low energy cost
- Supply power voltage variations do not affect light output
- Very low total lifetime costs
- Low wind load

### Specifications met

- ICAO International Standards and Recommended Practices:
- Aerodromes - Annex 14 Volume 1, 5th Edition, July 2009, Chapter 6: Low-intensity, Type B Fixed Obstacle Light
- FM Advisory Circular 150/5345-43F 09/12/06 L-810 Light Unit

### Optical characteristics

- Intensity better than 32cd
- Colour aviation red
- Horizontal radiation pattern 360°
- Vertical radiation pattern 15°
- LED supply current stabilised by constant current generator
- Light output degradation less than 30% after 100.000hrs of operation

### Electrical characteristics

- Input voltage range 10-60V<sub>DC</sub>
- Power consumption less than 3W
- Over voltage protection

### Mechanical characteristics

- Anodised marine grade aluminium body and end parts
- AISI 316 acid proof steel screws
- Colourless (clear) glass cover
- Terminal box for 1, 5 - 6mm<sup>2</sup> wires
- Degree of protection IP65
- Operating temperature range -55°C to +55°C
- Height 210mm, diameter 104mm, weight 1.1kg
- Wind load with CEL-MS-EV60 mounting kit @ 200km/h less than 40N

### Options

- Mounting kits
- Photocell & Flasher: CEL-LI-32-DCW-PCFL

Order Code: **CEL-LI-32-DCW-F**



CEL-LI-32-DCW-F

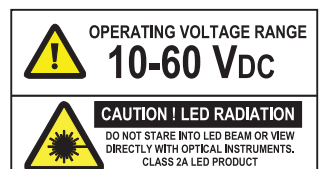

T: +44 (0)20 8540 1034  
F: +44 (0)20 8543 3058  
E: info@contarnex.com

Contarnex Europe Limited  
252 Martin Way,  
Morden, Surrey SM4 4AW  
United Kingdom



# 32cd Low-intensity Obstruction Light

## 10-60V<sub>DC</sub> - ICAO Type B. FAA L-810.

### CEL-LI-32-DCW-F - LED Aircraft Warning Light

#### ELECTRICAL INSTALLATION INSTRUCTIONS

**CEL-LI-32-DCW-F has two cable glands for easy chaining without external distribution boxes**

CEL-LI-32-DCW-F is an obstacle light utilizing LED technology. The cabling and installation principles are similar to those of conventional obstacle lights.

Connection can be protected with a 6A or 10A fuse or with a circuit breaker (C curve).

#### Installation specifications

- Cable gland: M25
- Cable diameter: 11 to 17mm
- Wire diameter: max. 6mm<sup>2</sup>
- Recommended cable: 3x1.5mm<sup>2</sup> or 3x2.5mm<sup>2</sup>

#### Options

- **CGS-20:** Smaller cable glands  
Set include 2 pcs M20 cable glands with M25-M20 adapters for 7-13 mm cables

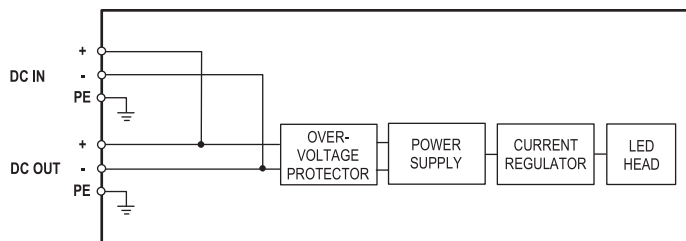
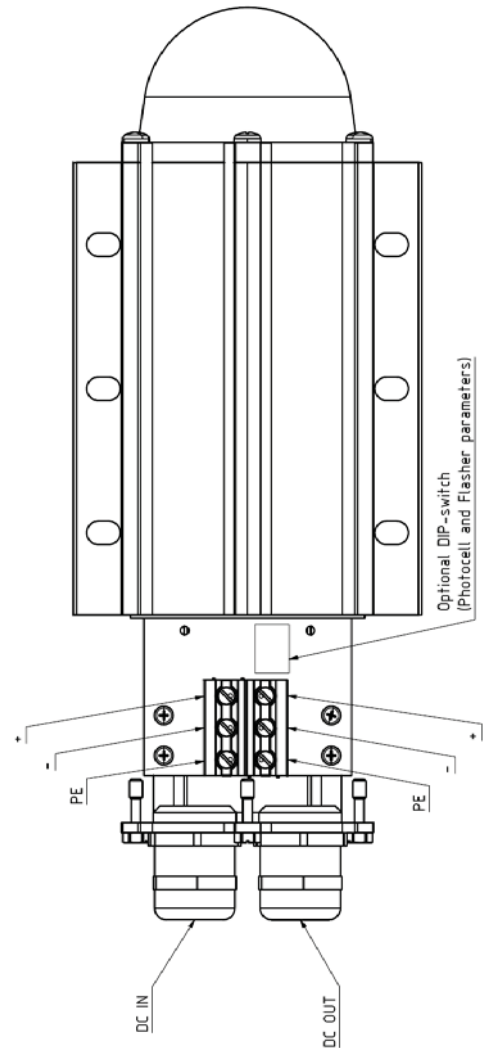

LI-32-DCW-F block diagram

# 32cd Low-intensity Obstruction Light

10-60V<sub>DC</sub> - ICAO Type B. FAA L-810.

CEL-LI-32-DCW-F - LED Aircraft Warning Light

## Mechanical dimensions

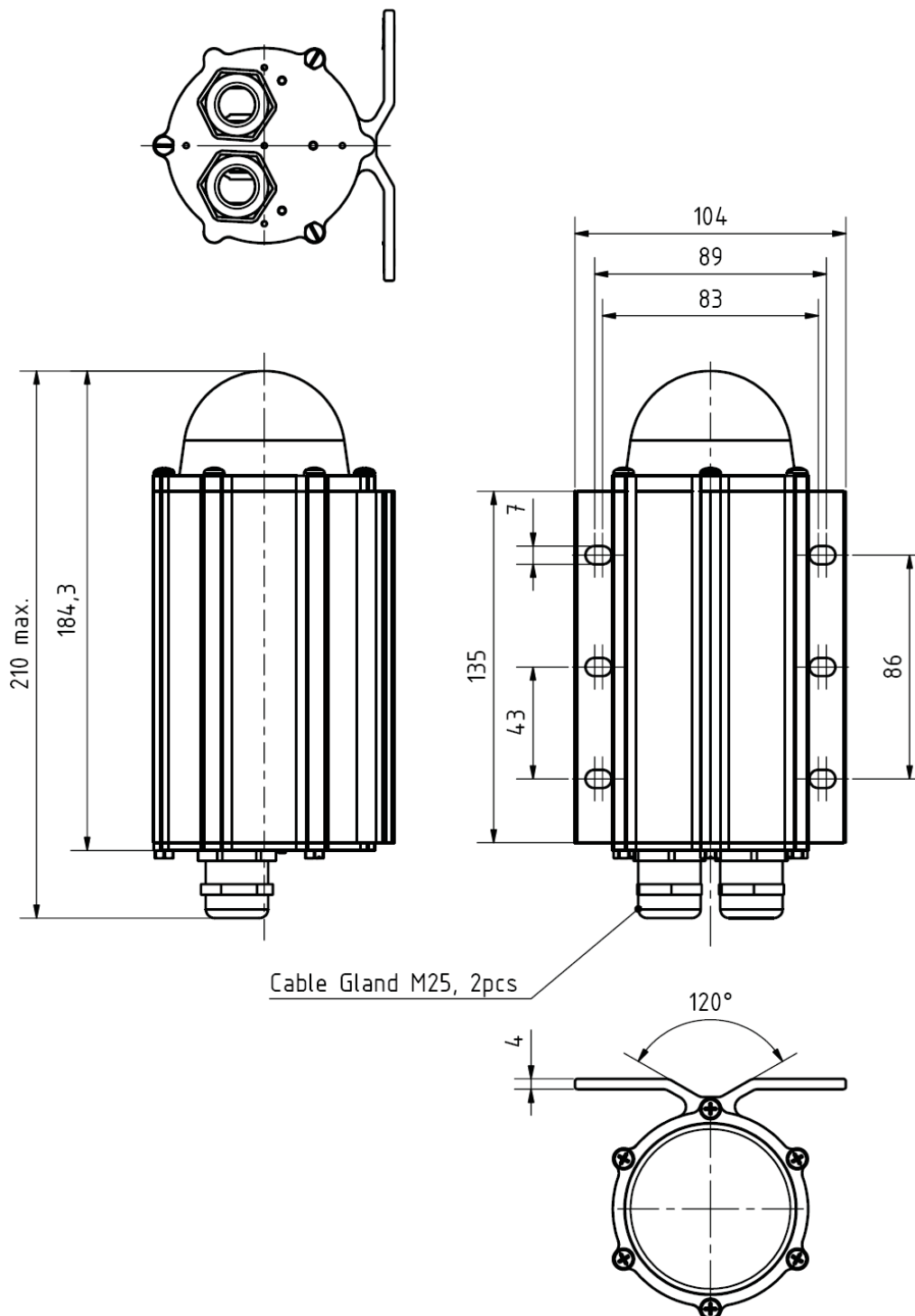

# 32cd Low-intensity Obstruction Light 10-60V<sub>DC</sub> - ICAO Type B. FAA L-810. CEL-LI-32-DCW-F - LED Aircraft Warning Light

There are several types of mounting sets available as option:

## CEL-MS-HV80

Mounting set for 33-80mm vertical or horizontal pipe

Mounting set include:

- 2 pcs M6 U-bolt
- 8 pcs M6 hex nut
- 4 pcs 6/12 mm washer

All parts AISI 316 acid proof steel

More detailed mechanical data: CEL-MS-HV80 datasheet

Order Code: **CEL-MS-HV80**

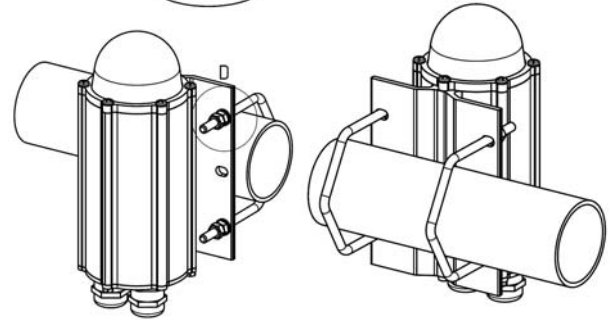
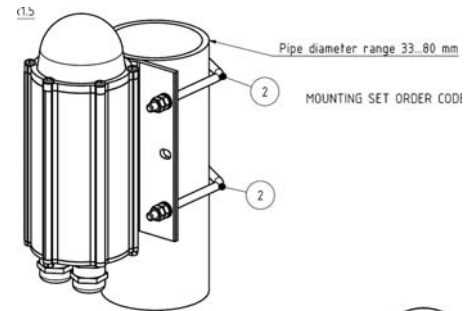

## CEL-MS-EV60

Mounting set with extension plate for 30-60mm vertical pipe installation

Mounting set include:

- 2 pcs M8 U-bolt, 8 pcs M8 hex nut
- 4 pcs M6x30 bolt, 8 pcs M6 hex nut, 4 pcs 6/12 washer
- 1 pcs extension plate

Extension plate marine grade anodised aluminium, other parts AISI 316 acid proof steel

More detailed mechanical data: CEL-MS-EV60 datasheet

Order Code: **CEL-MS-EV60**

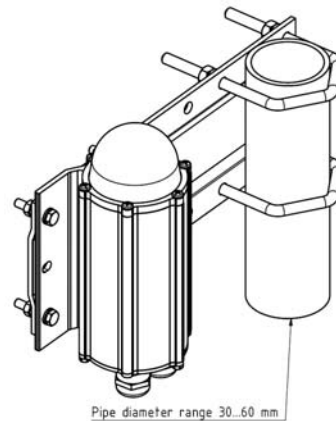

## CEL-MS-EV100:

Mounting set with extension plate for 60-100mm vertical pipe installation

Mounting set include:

- 2 pcs M8 U-bolt, 8 pcs M8 hex nut
- 4 pcs M6x30 bolt, 8 pcs M6 hex nut, 4 pcs 6/12 washer
- 1 pcs extension plate

Extension plate marine grade anodised aluminium, other parts AISI 316 acid proof steel

More detailed mechanical data: CEL-MS-EV100 datasheet

Order Code: **CEL-MS-EV100**

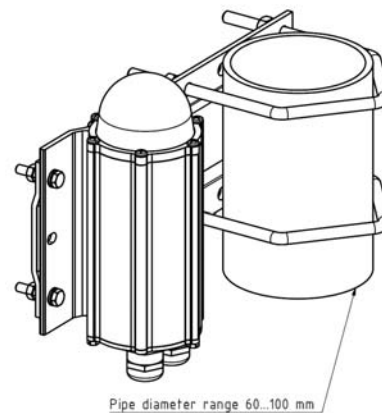

# 32cd Low-intensity Obstruction Light

## 10-60V<sub>DC</sub> - ICAO Type B. FAA L-810.

### CEL-LI-32-DCW-F - LED Aircraft Warning Light

#### CEL-MS-EV150:

Mounting set with extension plate for 100-150mm vertical pipe installation

Mounting set include:

- 2 pcs M8 U-bolt, 8 pcs M8 hex nut
- 4 pcs M6x30 bolt, 8 pcs M6 hex nut, 4 pcs 6/12 washer
- 1 pcs extension plate

Extension plate hot dipped galvanised steel, other parts AISI 316 acid proof steel

More detailed mechanical data: CEL-MS-EV150 datasheet

Order Code: **CEL-MS-EV150**

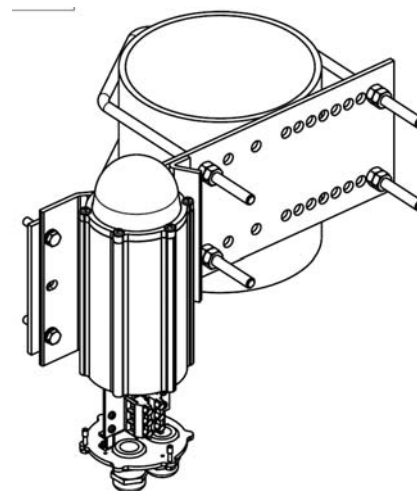

#### CEL-MS-DEV60:

Double mounting set with extension plate for 30-60mm vertical pipe installation

Mounting set include:

- 2 pcs M8 U-bolt, 8 pcs M8 hex nut
- 8 pcs M6x30 bolt, 16 pcs M6 hex nut, 8 pcs 6/12 washer
- 1 pcs extension plate

Extension plate marine grade anodised aluminium, other parts AISI 316 acid proof steel

More detailed mechanical data: CEL-MS-DEV60 datasheet

Order Code: **CEL-MS-DEV60**

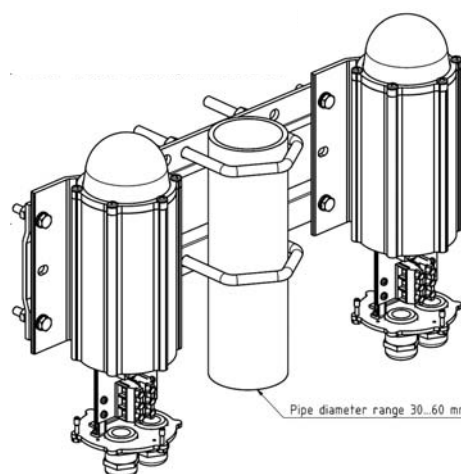

#### CEL-MS-DEV100:

Double mounting set with extension plate for 60-100mm vertical pipe installation

Mounting set include:

- 2 pcs M8 U-bolt, 8 pcs M8 hex nut
- 8 pcs M6x30 bolt, 16 pcs M6 hex nut, 8 pcs 6/12 washer
- 1 pcs extension plate

Extension plate marine grade anodised aluminium, other parts AISI 316 acid proof steel

More detailed mechanical data: CEL-MS-DEV100 datasheet

Order Code: **CEL-MS-DEV100**

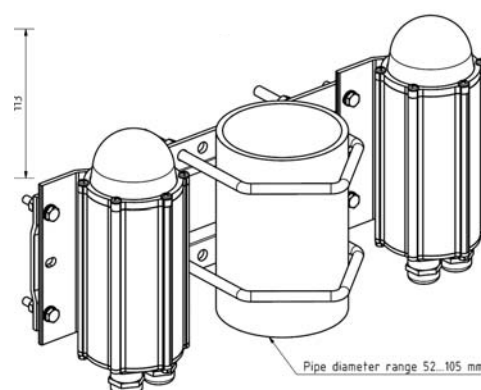

# 32cd Low-intensity Obstruction Light

## 10-60V<sub>DC</sub> - ICAO Type B. FAA L-810.

### CEL-LI-32-DCW-F - LED Aircraft Warning Light

#### CEL-MS-RW

Mounting set for horizontal plate or wall installation

Mounting set include:

- 4 pcs M6x30 bolt, 8 pcs M6 hex nut, 4 pcs 6/12 washer
- 1 pcs L-shape 2mm plate

All parts AISI 316 acid proof steel

More detailed mechanical data: CEL-MS-RW datasheet

Order Code: **CEL-MS-RW**

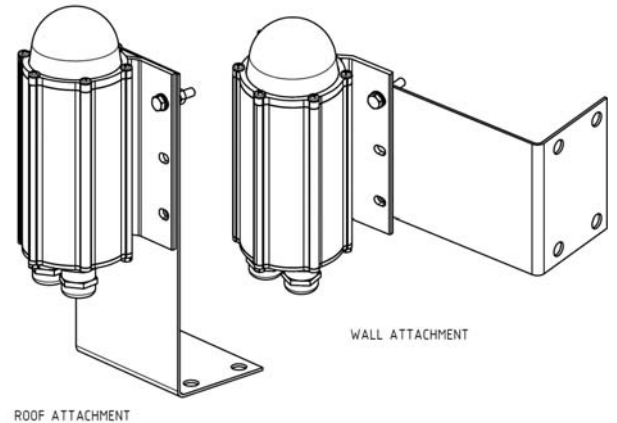

#### CEL-MS-LVU

Mounting set for Land V -shape profiles

Mounting set include:

- 1 set accessories for light unit fitting to plate
- 1 pcs extension plate with adjusting plate and accessories

Extension plate hot dip galvanized steel, other parts AISI 316 acid proof steel

More detailed mechanical data: CEL-MS-LVU datasheet

Order Code: **CEL-MS-LVU** (with galvanized extension plate)

**CEL-MS-LVA** (with AISI 316 extension plate)

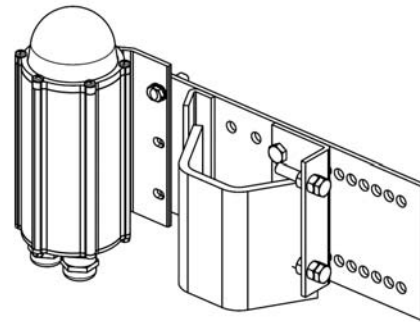

#### CEL-MS-N1B

Mounting set for 1" NPT at bottom

More detailed mechanical dimensions: CEL-MS-N1B dataheet

Order Code: **CEL-MS-N1B**

